

Specifications

MODEL	GTH™-5519	
MEASUREMENTS	US	Metric
Maximum lift height	19 ft	5.79 m
Reach	11 ft	3.35 m
Reach at maximum height	1 ft 10 in	0.56 m
A Height, stowed	6 ft 4 in	1.93 m
B Length, stowed (without forks)	12 ft 7 in	3.84 m
Width	5 ft 11 in	1.80 m
C Wheelbase	7 ft 7 in	2.32 m
D Ground clearance, center	1 ft 1 in	0.33 m
E Ground clearance, axle	10 in	0.25 m
Fork cross section	1.6 x 4 in	40 x 100 mm

PRODUCTIVITY		
Maximum lift capacity	5,500 lbs	2,500 kg
Lift capacity at maximum height	4,400 lbs	1,995 kg
Lift capacity at maximum reach	1,900 lbs	862 kg
Drive speed	15 mph	24.1 km/h
Draw bar pull	9,300 lbs	4,225 kg
Break out force	8,100 lbs	3,674 kg
Turning radius, outside (4WS)	11 ft	3.35 m
Auxiliary hydraulic flow	18.5 gpm	70 lpm
Auxiliary hydraulic pressure	3,918 psi	270 bar
Tires, standard size	12 x 16.5 in, 10 ply	

POWER		
Power source	Perkins 804D-33 4 cylinder diesel 63 hp (47.0 kW) Deutz D 2011 4 cylinder diesel 68 hp (50.0 kW)	
Electrical system	System voltage 12 volt Alternator 95 amp Battery 720 CCA at 0°F (-18°C)	
Hydraulic tank capacity	16.4 gal	62 L
Hydraulic system capacity (w/tank)	25 gal	95 L
Fuel tank capacity	15.9 gal	60 L

WEIGHT		
Weight*	9,800 lbs	4,450 kg

STANDARDS COMPLIANCE	ANSI/ITSDF B56.6, CSA B335
----------------------	----------------------------

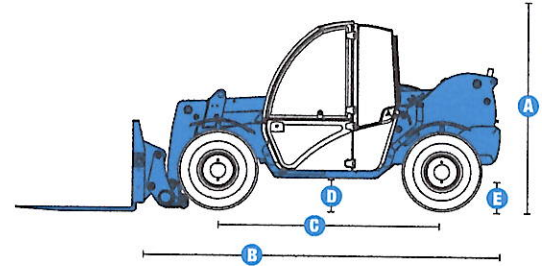

LOAD CHART GTH™-5519**

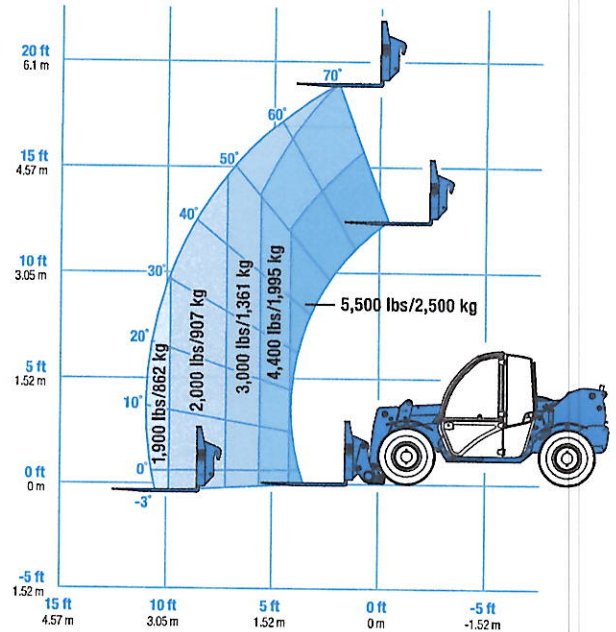

* Weight will vary depending on options and/or country standards.
 ** Load ratings vary depending on attachment.

Features

STANDARD FEATURES

MEASUREMENTS

- 5,500 lb (2,500 kg) maximum lift capacity
- 19 ft (5.79 m) maximum lift height
- 11 ft (3.35 m) maximum reach

PRODUCTIVITY

- Full time planetary 4-wheel drive
- 4WS
- Operator selectable front, crab, coordinated steering modes
- Auxiliary hydraulic circuit
- Proportional, reversible, continuous auxiliary hydraulic flow control
- Genie manual Quick-Attach™ system
- Power assisted steering
- Variable speed hydrostatic drive
- Limited slip front axle differential
- Inboard wet disc service brakes
- Wet disc spring applied parking brake
- 12 x 16.5 in, air-filled rough terrain tires
- Fenders (set of 4)
- ROPS/FOPS canopy (ISO compliant)
- Single multi-function proportional joystick
- Tilt steering column
- Illuminated gauge and switch panels
- Retractable seat belt
- Machine level indicator
- Right-side screen guard
- 48 inch carriage and pallet forks
- Boom angle indicator
- Reverse motion alarm

OPTIONS & ACCESSORIES

PRODUCTIVITY OPTIONS

- Enclosed cab, includes split door, emergency exit, clip-in glass inserts, front wiper and tank, cab heater
- Cab air conditioner
- Adjustable suspension seat
- 3 in retractable seat belt
- Flashing beacon
- Work lights
- Road lights
- Exhaust scrubber

ATTACHING SYSTEM OPTIONS

- Universal skid steer adapter
- Auxiliary hydraulic back pressure
- Hydraulic quick attach

ATTACHMENT OPTIONS

- Carriages
 - 48 in (1.22 m) side shift carriage, +/- 4 in (10 cm)
 - 48 in (1.22 m) rotating fork carriage, +/- 14°
- Forks (in addition to standard 48 in pallet forks)
 - 60 in (1.52 m) forks
 - 48 in (1.22 m) forks (ITA type)
 - Cubing tines, 2 x 2 x 48 in (.05 x .05 x 1.22 m)
- Buckets
 - 66 in bucket with bolt-on cutting edge, .50/.65 yd³ struck/heaped
 - 60 in bucket with bolt-on cutting edge, .65/.75 yd³ struck/heaped
 - 78 in, .68 yd³ scrap grapple bucket
- 6 ft truss boom

ENGINE OPTIONS

- Perkins 63 hp (47 kW) diesel engine
- Deutz 68 hp (50 kW) diesel engine



TIRE OPTIONS

- 12 x 16.5 in, semi-pneumatic solid rough terrain tires
- 12 x 16.5 in, foam-filled tires

Genie United States

18340 NE 76th Street
P.O. Box 97030
Redmond, Washington 98073-9730
Telephone +1 (425) 881-1800
Toll Free in USA/Canada +1 (800)-536-1800
Fax +1 (425) 883-3475

Genie Europe

The Maltings
Wharf Road
Grantham NG31 6BH
UK
Telephone +44 (0)1476 584333
Fax +44 (0)1476 584334
Email: AWP-InfoEurope@terex.com

Distributed By:

Effective Date: April, 2011. Product specifications and prices are subject to change without notice or obligation. The photographs and/or drawings in this document are for illustrative purposes only. Refer to the appropriate Operator's Manual for instructions on the proper use of this equipment. Failure to follow the appropriate Operator's Manual when using our equipment or to otherwise act irresponsibly may result in serious injury or death. The only warranty applicable to our equipment is the standard written warranty applicable to the particular product and sale and we make no other warranty, express or implied. Products and services listed may be trademarks, service marks or trade-names of Terex Corporation, Genie Industries, Inc. and/or their subsidiaries in the U.S.A. and many other countries and all rights are reserved. Terex® is a Registered Trademark of Terex Corporation in the U.S.A. and many other countries. Genie® is a Registered Trademark of Genie Industries, Inc. in the U.S.A. and many other countries. Genie is a Terex Brand. © 2011 Terex Corporation.